WTV010 & WTV020

Datasheet

1.Features.....	2
2. Chip models.....	2
3. Package sketch map	2
4.Pin's descriptions.....	3
4.2. WTV020 SOP20/SSOP20 Package	4
5. Electric parameters.....	4
6.Absolute maximum ratings.....	5
7. Pins detail functions (D0 D8).....	5
8.Control modes	6
8.1. Keyboard	6
8.2. Parallel interface (COM+SBT)	8
8.3. One line serial interface	9
8.4. Two lines serial interface (For external SD card using).....	11
8.5. Three lines serial interface.....	11
9.Typical application circuits	12
9.1. Keyboard mode PWM output (Direct drive speaker).....	12
9.2. Keyboard mode DAC output (External amplifier).....	13
9.3. WTV010/WTV020 DIP16/SOP16/TSSOP16 ,parallel interface(COM+SBT) mode PWM output.....	13
9.4. WTV010/WTV020 DIP16/SOP16/TSSOP16 , one line serial interface PWM output.....	14
9.5. WTV010/WTV020 DIP16/SOP16/TSSOP16 , three lines serial interface PWM output.....	14
9.6. WTV020-20S/SS , Parallel (COM+SBT) interface PWM output.....	15
9.7.WTV020-20S/SS , one line serial interface PWM output.....	15
9.8. WTV020-20S/SS two lines serial interface PWM output.....	16
10. Packages and Pins	17
10.1. DIP 16 dimension	17
10.2. SOP16 dimension.....	18
10.3. SOP20 dimension.....	18
10.4. TSSOP16 dimension	19
11.Timing control.....	21
11.1.Timing control waveform	21
11.2.Timing value.....	22
12. One line , three line serial interface control flow	22
13. One serial interface program	23
13.1.One line serial finterface Assembly.....	23
13.2.One line serial interface C program	24
14. Three lines serial interface progarm.....	26
14.1. Three lines serial interface Assembly	26
14.2. Three lines serial interface C program.....	27
15. Supply information	29
16. Versions	29

1.Features

- *OTP(one time programmable) VOICE-CHIP
- *Operating voltage:2.5V-3.6V
- * WTV010 with 10seconds , WTV020 with 20seconds duration at 6KHz .
- *Sampling rate supported form 6KHz ,8KHz,10KHZ 32KHz max.
- *Higher sampling rate better sound quality and shorter duration.
- *With DAC and PWM audio output .
- *DAC output connect to amplifier . PWM output can direct a 0.5W/8ohms speaker
- *Equipped with 16 bits DAC
- * Mute will not take up any memory space.
- * The same voices can be re-use and will not take up memory space.
- *Multiple control modes: key mode(keyboard), parallel (COM+SBT), one line serial , two lines serial , three lines serial
- * Quiescent current 2uA
- *Support WAV ,16Bit, mono format.
- *Equip with PC software for project editing.

2. Chip models

WTV010/WTV020

Model	WTV010-DIP16/SOP16/TSSOP	WTV020-DIP16/SOP16/TSSOP	WTV020-SOP/SSOP20
	16	16	
Duration	10 s	20 s	20 s
Track	Mono	Mono	Mono
Audio output	DAC/PWM	DAC/PWM	DAC/PWM
Key board trigger I/O	4	4	7
Parallel address	4	4	7
Control modes	Keyboard / parallel(COM+SBT)/Serial	Keyboard / parallel(COM+SBT)/Serial	Keyboard / parallel(COM+SBT)/Serial

Note:The duation caculate at 6KHz sampling rate ,Control modes can be chosen in PC software.

3. Package sketch map

WTV010 with DIP 16 and SOP 16 package.

And WTV020 with DIP 16 and SOP 16 and TSSOP 16 and SOP 20 and SSOP 20 Package.

= : 60• = : 90• = : < :0• = : < 60• = : < 90• = : 9

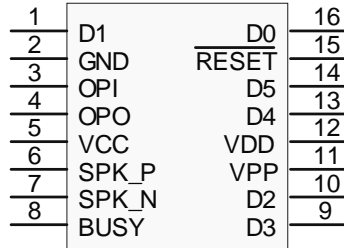

= : < 9 = : < 9 9

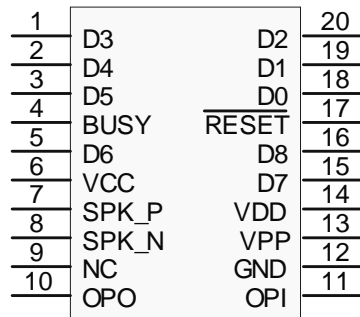

4.Pin’s descriptions

4.1 For WTV010/WTV020 DIP16/SOP16/TSSOP16 package

Pin No.	Pin name	Brief	Descriptions
1	D1	K2/A0/CS	Keyboard trigger I/O / Parallel address / Three lines serial CS(Chip select)
2	GND	GND	GND
3	OPI	OPI	Internal amplifier reactive input
4	OPO	OPO	Internal amplifier reactive output
5	VCC	VCC	Chip analog power
6	SPK-P	SPK-P	DAC /PWM audio output
7	SPK-N	SPK-N	DAC /PWM audio output
8	BUSY	BUSY	Busy
9	D3	K4/A2/DI	Keyboard trigger I/O , Parallel address/ one line data /two lines serial data / three lines serial data
10	D2	K3/A1/SCK	Keyboard trigger I/O / Parallel address / Two lines serial Clock/Three lines serial Clock
11	VPP	VPP	Chip program power
12	VDD	VDD	Chip digital power
13	D4	A3	Parallel address
14	D5	D5	Data
15	RESET	RESET	Chip reset (keep low level 2ms to reset)
16	D0	K1 TEST/SBT	Keyboard trigger I/O / Parallel address trigger SBT

4.2. WTV020 SOP20/SSOP20 package

Pin No.	Pin name	Brief	Descriptionss
1	D3	K3/A5	Keyboard trigger I/O / Parallel address
2	D4	K4/A1/SCK	Keyboard trigger I/O /Two lines serial Clock/Three lines serial Clock / Parallel address
3	D5	K5/A2/DI	Keyboard trigger I/O , Parallel address/ one line serial data / two lines serial data / three lines serial data
4	BUSY	BSUY	Busy
5	D6	K6/A6	Keyboard trigger I/O / Parallel address
6	VCC	VCC	Chip analog power
7	SPK-P	SPK-P	DAC/PWM audio output
8	SPK-N	SPK-N	DAC/PWM audio output
9	NC	NC	N/C
10	OPO	OPO	Internal amplifier reactive output
11	OPI	OPI	Internal amplifier reactive input
12	GND	GND	GND
13	VPP	VPP	Chip program power
14	VDD	VDD	Chip digital power
15	D7	A3	Parallel address
16	D8	--	Parallel address
17	RESET	RESET	Chip reset (keep low level 2ms to reset)
18	D0	K0/SBT	Keyboard trigger I/O / Parallel address trigger pin
19	D1	K1/CS/A0	Keyboard trigger I/O / Parallel address/ three lines serial CS (chip select)
20	D2	K2/A4	Keyboard trigger I/O / Parallel address

5. Electric parameters

Pin names	Parameters	Min.	Typ.	Max.	Unit	Conditions
D7 D8	Drive current		4		mA	VOH=2.7
OP_O	Drive current		4		mA	
SPK_P SPK_N	Drive current			80 150	mA	RL=8 Ω
D0 D1	Output current		4		mA	VOL=0.3
OP_O	Output current		4		mA	VOL=0.3
SPK_P SPK_N	Output current			80 150	mA	RL=8 Ω
I_STD	Quiescent current	0.5	1	2	uA	

6. Absolute maximum ratings

Item	Range	Unit	
VCC-GND	-0.5 4.5	V	
Vin	GND-0.3<Vin<VCC+0.3	V	
Vout	GND<Vout<VCC	V	
T(Operation)	DIP	-30~+75	°C
	SOP	-40~+85	°C
T(Junction)	-30~+120	°C	
T(Storage)	-45~+125	°C	

7. Pins detail functions (D0 D8)

The pins functions in different control mode for DIP16/SOP16/TSSOP package

In the Parallel mode, D0 works as trigger Pin (SBT) .In the keyboard mode , D0~D6 can be defined as pulse retrigger, pulse trigger, low level trigger, low level retrigger, ON/OFF, up(previous) ,down (next) ,up loop, down loop .

D1 is defined as key trigger I/O ,/ three lines serial CS / and parallel address A0

D2 is defined as key trigger I/O /two lines serial clock / three lines serial clock / parallel address A1

D3 is defined as key trigger I/O / one line serial data in / two lines serial data in / three lines serial data in / parallel address A2

D4 is defined as key trigger I/O / parallel address A3

The pins functions in different control mode for SOP20 package

In the parallel interface , D0 works as trigger pin (SBT) .

D1 is defined as key trigger I/O / three lines serial CS(chip select) / parallel address A0

D2 is defined as key trigger I/O / parallel address A4

D3 is defined as key trigger I/O / parallel address A5

D4 is defined as key trigger I/O /two lines serial clock / three lines serial clock / parallel address A1

D5 is defined as key trigger I/O / one line serial data / two lines serial data / three lines serial data / parallel address A2

D6 is defined as key trigger I/O / parallel address A6

D7 is defined as parallel address A3

VDD ,VCC,GND

VDD is chip digital power input, VCC is chip analog power input , voltage range from 2.6V 3.6V .

GND is power ground .

OPO , OPI , SPK-P, SPK-N

OPO is chip internal amplifier reactive output pin, OPI is chip internal amplifier reactive input pin . When use the PWM output to direct speaker , the reactive circuit should be connected .When use DAC output to connect external amplifier , reactive circuit is not needed. SPK ÉP and SPK-N are audio output , connect 0.5W/8ohms speaker when PWM output . When DAC output, OPO connect a capacitor to amplifier input, and share GND. Pls see the application circuit.

RESET ,BUSY

Low level reset the chip , this low level not less than 2ms ,after reset , pull up not less than 5ms , will let the chip into working. Busy can be set to low or high output in the software .

8.Control modes

WTV010/WTV020 with keyboard, one line serial , two lines serial , three lines serial and parallel interface control modes. User can choose the mode in the PC software before program sounds into the chip.

8.1. Keyboard

In this mode, each I/O can trigger one ground of sound ,and the trigger mode can be set individually. Debounce time is 10ms in key mode. The trigger mode include Pulse retrigger, pulse trigger, level retrigger, level trigger, on/off, down, up ,down loop , up loop , the detail function please see the waveform.

8.1.1.Pulse retrigger

Negative pulse trigger, when I/O port detect falling edge (such as short touch the I/O port to the GND), trigger and play voice. During the playing , falling edge was detected again, the voice will be interrupted and re-play.

8.1.2. Pulse trigger

Negative pulse trigger, when I/O port detect falling edge (such as short touch the I/O port to the GND), trigger and play voice. During playing ,even falling edge was detected again, the chip will not take other action.After voice played over, falling edge become valid to trigger sound .

8.1.3. Level retrigger

Level retrigger. When I/O port is low level, keep playing , high level will stop. it will re-play until high level.

8.1.4 Level trigger

Level trigger When I/O port is low level, keep playing , high level will stop. After first play is over it won't replay even keep low level. Unless pull high then pull low and keep low level, it will be the second play .

8.1.5. On/off

A negative pulse start to play, next negative pulse to stop.

8.1.6. Down (Next)

Next(down) .A negative trigger play a group, next negative trigger play next group, untill last group, then no more voice can be triggered.

8.1.7.Up (Previous)

Previous (Up) A negative pulse trigger to play a group, next negative pulse trigger to play previous group . it will not loop after all voices triggered.

8.1.8. Down loop

Next loop(down loop). A negative pulse trigger to play a group, next negative pulse trigger to play next group . It can be loop by trigger.

8.1.9. Up loop

Previous loop(up loop). A negative pulse trigger to play a group, next negative pulse trigger to play previous group . It can be loop by trigger.

8.2. Parallel interface (COM+SBT)

In this mode, D0 works as trigger Pin (SBT) , trigger different voices in different address .

8.2.1 Assignment of I/O

Package	Pins								
	D8	D7	D6	D5	D4	D3	D2	D1	D0
DIP16	--	--	--	--	A3	A2	A1	A0	SBT
SOP16	--	--	--	--	A3	A2	A1	A0	SBT
SOP20	--	A3	A6	A2	A1	A5	A4	A0	SBT

8.2.2. The relation of address and voice for WTV020/WTV010 DIP16 ĀSOP16 ĀTSSOP16

Group N	Address pins			
	A3	A2	A1	A0
Group1	0	0	0	0
Group2	0	0	0	1
Group3	0	0	1	0
.....
Group14	1	1	0	1
Group15	1	1	1	0
Group16	1	1	1	1

8.2.3. The relation of address and voice for SOP20 package

Group N	Address pins							
	A7	A6	A5	A4	A3	A2	A1	A0
Group1	0	0	0	0	0	0	0	0
Group2	0	0	0	0	0	0	0	1
Group3	0	0	0	0	0	0	1	0
.....
Group126	1	1	0	1	1	0	1	0
Group127	1	1	0	1	1	0	1	1
Group128	1	1	0	1	1	1	0	0

8.2.4. Timing waveform for Parallel interface (COM+SBT)

Put the address first and trigger by SBT . the trigger mode can be changed in software.

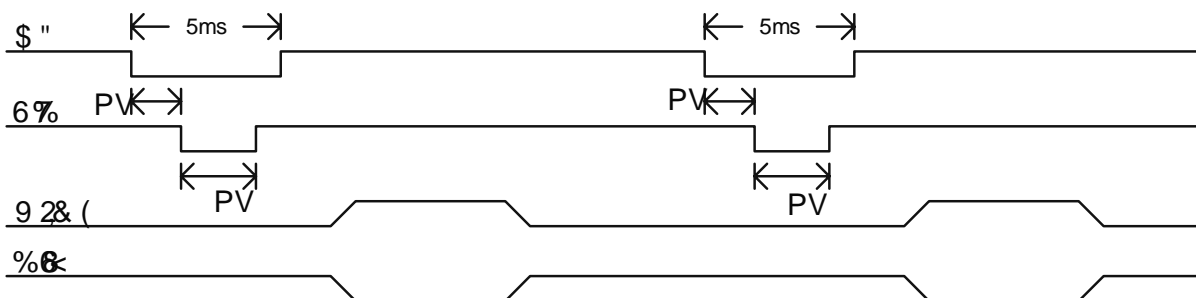

Note: ADD signal pull low 2ms ,SBT trigger and keep 2ms low level . avoid trigger other voices, after 1ms after SBT trigger finish , pull high ADD signal.

8.3. One line serial interface.

8.3.1. Assignment of I/O

Package	PIns								
	D8	D7	D6	D5	D4	D3	D2	D1	D0
DIP16	--	--	--	--	--	DATA	--	--	TEST

SOP16	--	--	--	--	--	DATA	--	--	TEST
SOP20	--	--	--	DATA	--	--	--	--	TEST

Note: D0 for voice test , negative pulses can trigger the voices .

8.3.3. Code descriptions

Code	Definition	Descriptions
E0H~EFH	Adjust volume	In standby or playing, there are 16 level volume can be adjusted, E0H is min. EFH is max.
F0H F1H	Built-in amplifier On or off	F0H turn off built-in amplifier F1H turn on built-in amplifier there should be 1ms delay after send this code
F2H	Repeat	During playing,send this code can repeat current voice
FEH	Stop	Stop the voice playing

Voices and addresses relationship

Code ÅHEX Å	Function
00H	Play group 1 voice
01H	Play group 2 voice
02H	Play group 3 voice
.....
CDH	Play group 206 voice
CEH	Play group 207 voice
CFH	Play group 208 voice

8.3.3. Timing waveform for one line serial interface

In one line serial mode , only have one DATA line , to represent different data bit by the different rate of low level and high level . High level : Low level =1:3 means “0” , High level : Low level =3:1 means “1” . High level first , then low level . Data , send low first , then send high .Please see the following waveform.

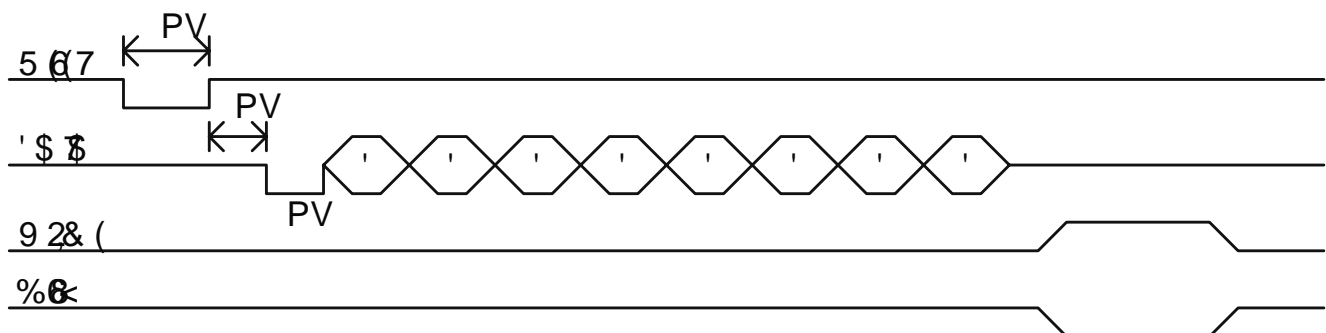

Note: Reset the chip before sending the data , if use battery power supply , this reset is not necessary . DATA pin is for data communication in one line serial interface . Waiting 5ms after reset ,then pull low 5ms to wake up the chip , then send data , high first , then low. 20ms after sent data, BUSY will have response. The data bit rate please see follows.



High level : Low level = 1 : 0 means "0"



High level : Low level = 3 : 1 means 1

8.3.4. Program examples

Please see at ["13. one line serial interface program."](#)

8.4. Two lines serial interface (For external SD card using)

Ignore

8.5. Three lines serial interface.

There are CS ,CLK ,DATA three lines communication. Imitate SPI communication .

8.5.1. Assignment of I/O

Package	Pins								
	D8	D7	D6	D5	D4	D3	D2	D1	D0
DIP16	--	--	--	--	--	DATA	CLK	CS	TEST
SO16	--	--	--	--	--	DATA	CLK	CS	TEST
SOP20	--	--	--	DATA	CLK	--	--	CS	TEST

Note: D0 for test , negative pulse trigger can play voices in all addresses .

8.5.2. Code descriptions

Code	Function	Descriptions
E0H~EFH	Adjust Volume	In playing or standby, send the code can adjust 16 level volume . E0H is minimum ÆEFH is maximum.
F0H F1H	Turn on/ off Am	F0H turn off internal amplifier ÆF1H turn on internal amplifier. It will be 1ms delay after send the code.
F2H	Repeat	During playing, send this code will repeat current address voice
FEH	Stop	Stop playing

The relationship between voices and addresses.

Data ÅHex. Å	Functions
00H	Play gourp 1 voice
01H	Play gourp 2 voice
02H	Play gourp 3 voice
.....
CDH	Play gourp 206 voice
CEH	Play gourp 207 voice
CFH	Play gourp 208 voice

8.5.3. Timing waveform for three lines serial interface

In three lines serial interface have CS , CLK and DATA . it is imitate SPI communication .

Reset should be pull low 5ms before send code ,then pull high not less than 5ms . Reset should stay high level. CS signal pull low 5ms to wake up chip , then send LCK and DATA , Clock cycle between 200us to 1ms , we suggest 400us .Data should send low first , then high . After data received , CS, CLK,DATA set to high level . After 20ms , BUSY will have response.

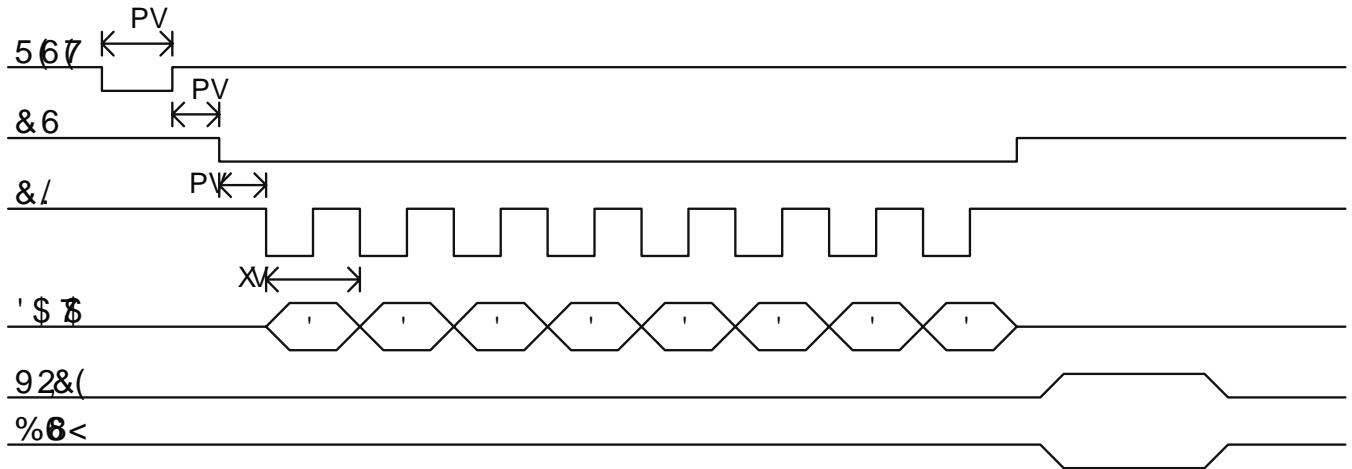

8.5.4. Program examples

Please see at ["14. three lines serial interface program."](#)

9. Typical application circuits

9.1. Keyboard mode PWM output (Direct drive speaker)

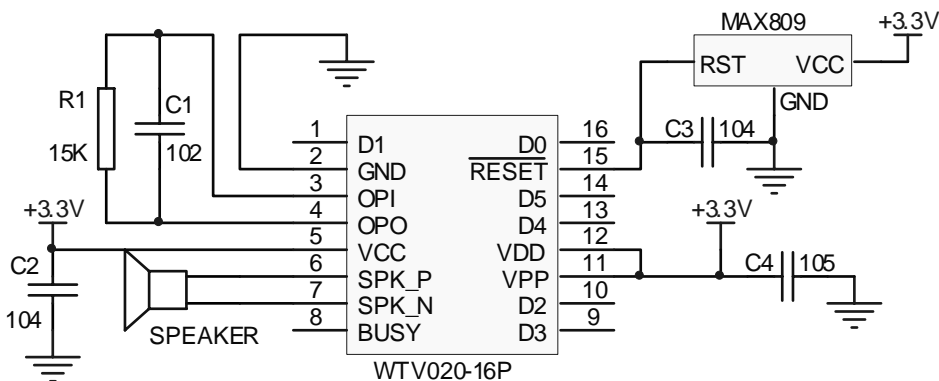

D0 D5 keep 10ms low level or give negative pulse , can trigger voice . BUSY will be low level during playing , other time will be high level. Reset should keep low level 5ms . R1 and C1 are for reactive circuit, change R1 value and change the volume output, 0 50K is ok , use 15K in circuit. Bigger volue ,higher sound volume. SPK can direct drive 0.5W/8 speaker in PWM output. VCC can be 2.5V 3.6V . If battery power this chip, it can be use capacitor connect GND to reset. If use DC power, it have to use reset circuit or MCU to reset.

9.4. WTV010/WTV020 DIP16/SOP16/TSSOP16 , one line serial interface PWM output

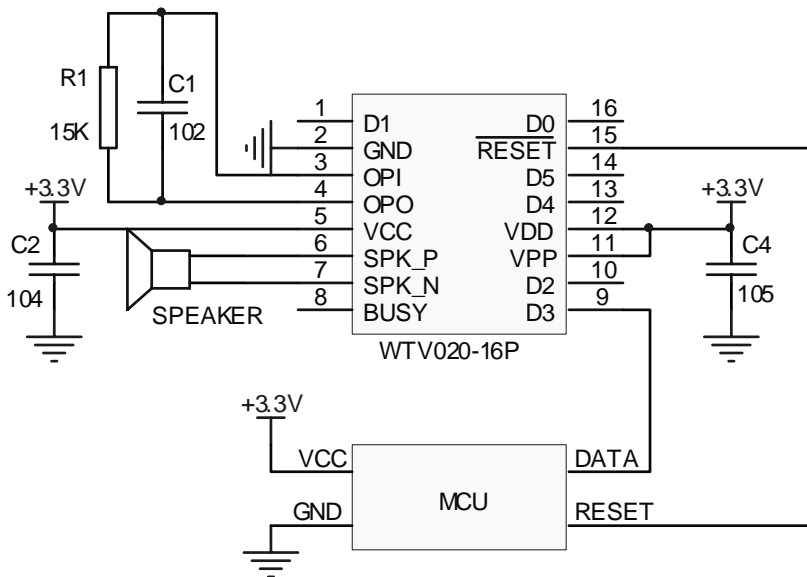

Mcu control WTV chip via DATA cable, Reset should keep low level 5ms . If MCU is 5V powered , you have to connect 470 resistors between MCU and WTV chips cables , because it is 3.3V power the WTV chip.

R1 and C1 are for reactive circuit, change R1 value and change the volume output, 0 50K is ok , use 15K in circuit. Bigger value ,higher sound volume. SPK can direct drive 0.5W/8 speaker in PWM output.

9.5. WTV010/WTV020 DIP16/SOP16/TSSOP16 , three lines serial interface PWM output

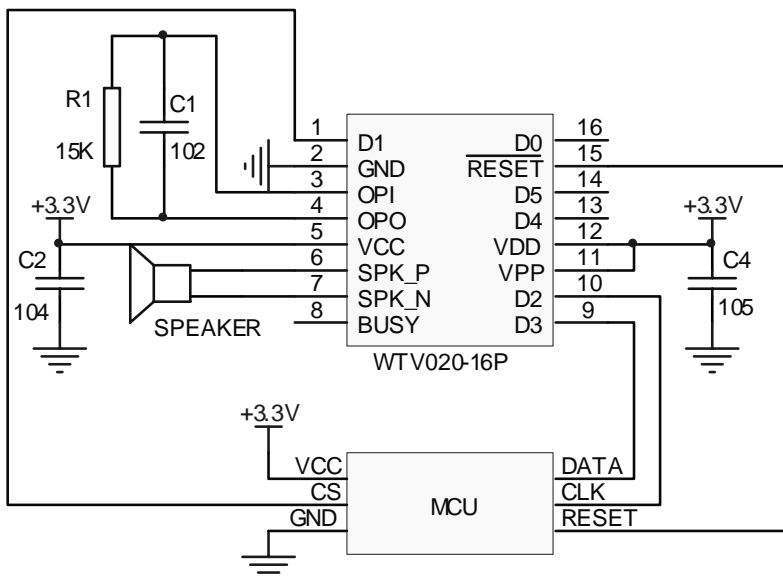

Mcu control WTV chip via CS,CLK and DATA cable, Reset should keep low level 5ms . If MCU is 5V powered , you have to connect 470 resistors between MCU and WTV chips cables , because it is 3.3V power the WTV chip.

R1 and C1 are for reactive circuit, change R1 value and change the volume output, 0 50K is ok , use 15K in circuit. Bigger value ,higher sound volume. SPK can direct drive 0.5W/8 speaker in PWM output.

9.6. WTV020-20S/SS , Parallel (COM+SBT) interface PWM output

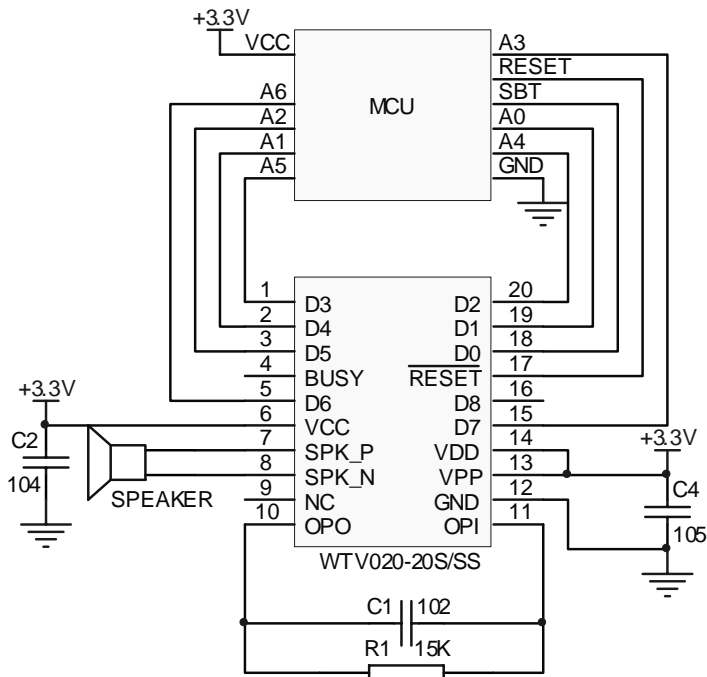

Mcu control WTV chip via A0 A6,then trigger the sound by SBT . Reset should keep low level 5ms . If MCU is 5V powered , you have to connect 470 resistors between MCU and WTV chips cables , because it is 3.3V power the WTV chip.

R1 and C1 are for reactive circuit, change R1 value and change the volume output, 0 50K is ok , use 15K in circuit. Bigger value ,higher sound volume. SPK can direct drive 0.5W/8 speaker in PWM output.

9.7.WTV020-20S/SS , one line serial interface PWM output

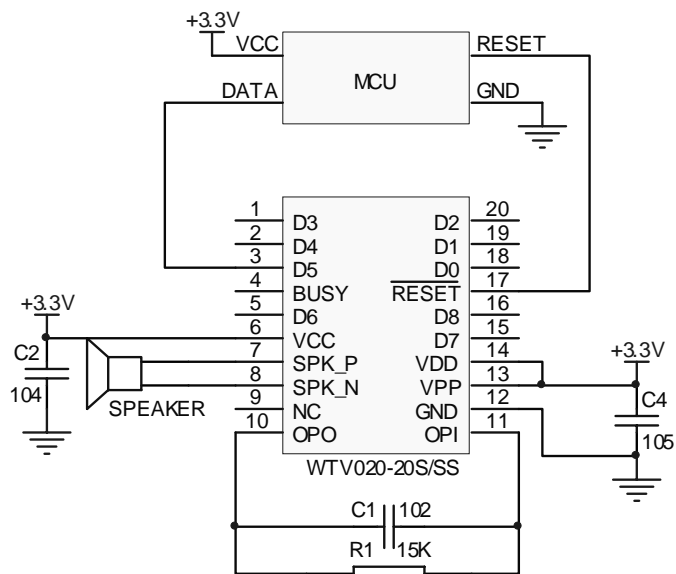

Mcu control WTV chip via DATA cable, Reset should keep low level 5ms . If MCU is 5V powered , you have to connect 470 resistors between MCU and WTV chips cables , because it is 3.3V power the WTV chip.

R1 and C1 are for reactive circuit, change R1 value and change the volume output, 0 50K is ok , use 15K in circuit. Bigger value ,higher sound volume. SPK can direct drive 0.5W/8 speaker in PWM output.

9.8. WTV020-20S/SS two lines serial interface e PWM output

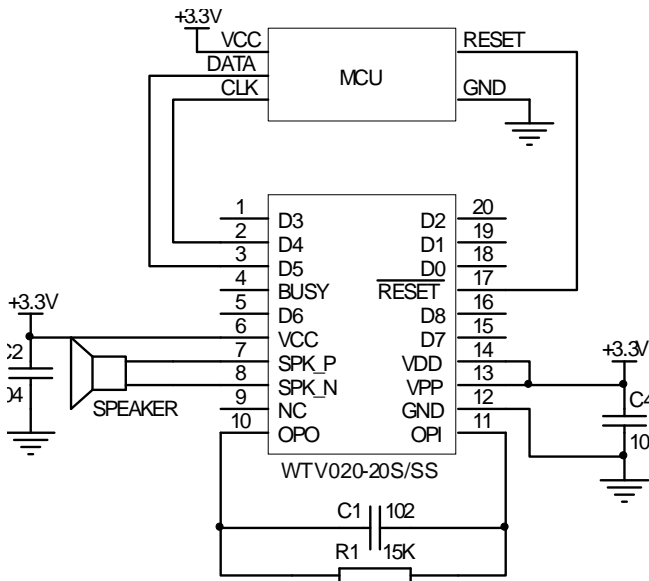

Mcu control WTV chip via DATA cable, Reset should keep low level 5ms . If MCU is 5V powered , you have to connect 470 resistors between MCU and WTV chips cables , because it is 3.3V power the WTV chip.

R1 and C1 are for reactive circuit, change R1 value and change the volume output, 0 50K is ok , use 15K in circuit. Bigger value ,higher sound volume. SPK can direct drive 0.5W/8 speaker in PWM output.

9.9. WTV020-20S/SS three lines serial interface PWM output

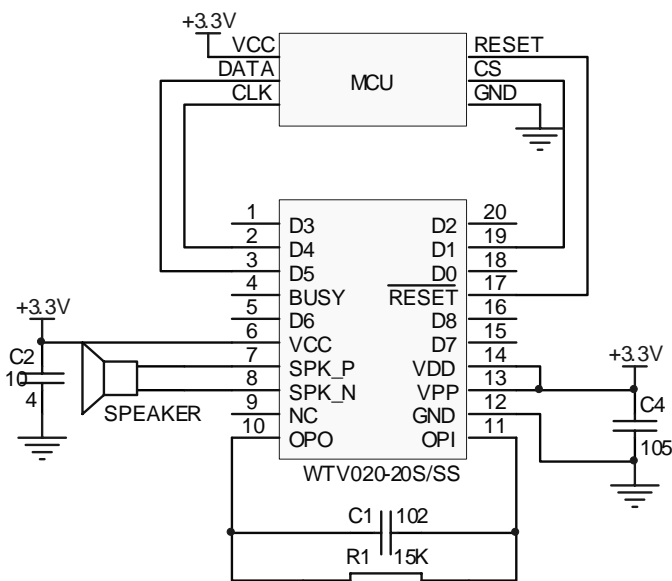

Mcu control WTV chip via CS,CLK and DATA cable, Reset should keep low level 5ms . If MCU is 5V powered , you have to connect 470 resistors between MCU and WTV chips cables , because it is 3.3V power the WTV chip.

R1 and C1 are for reactive circuit, change R1 value and change the volume output, 0 50K is ok , use 15K in circuit.

circuit. Bigger value ,higher sound volume. SPK can direct drive 0.5W/8 speaker in PWM output.

10. Package s and Pins

10.1. DIP 16 dimension

10.2. SOP16 dimension

10.3. SOP20 dimension

9 9 5 6

10.5. TSSOP16 dimension

11. Timing control

11.1. Timing control waveform

Keyboard

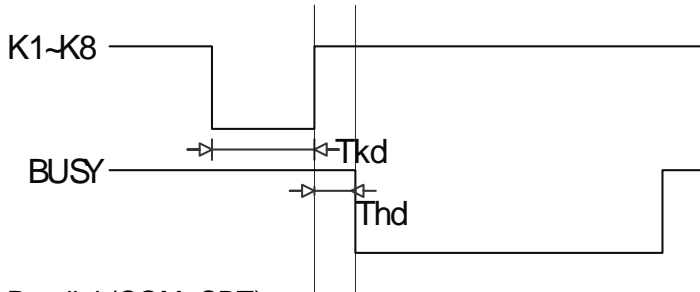

Parallel (COM+SBT)

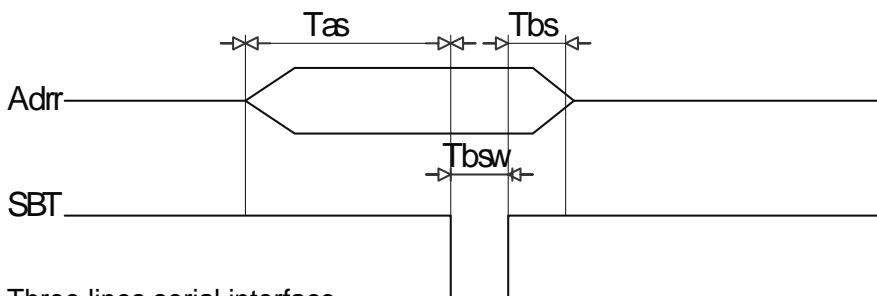

Three lines serial interface

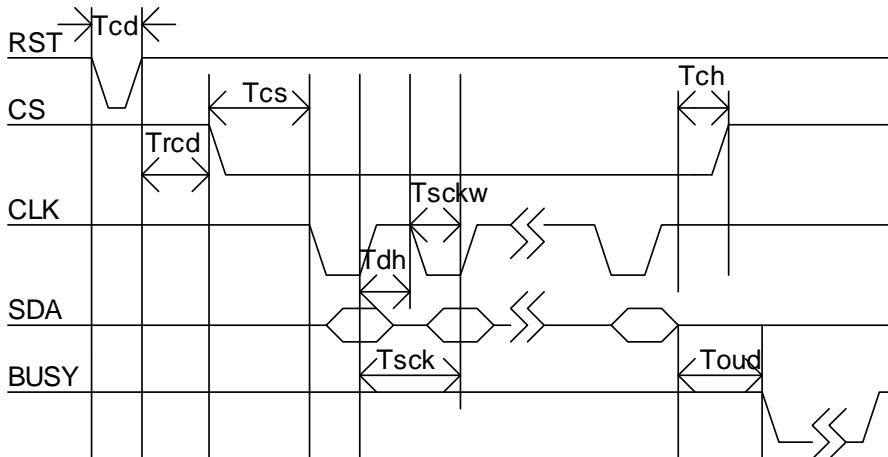

Two line serial interface

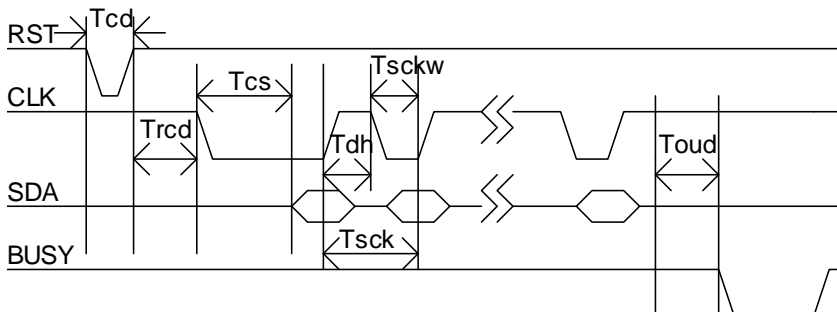

One line serial interface

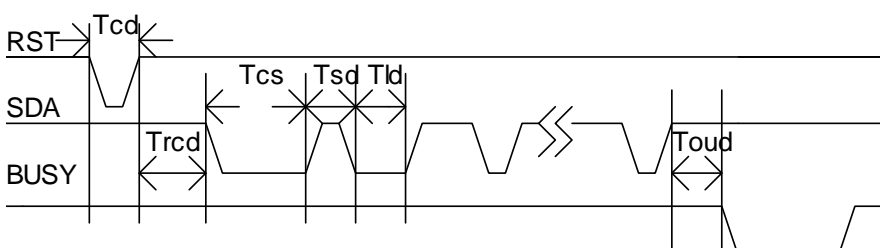

11.2.Timing value

Symbol	Description	Min.	Typical	Max.	Unit
Tkd	Keyboard delay time	10	20	25	MS
Thd	Busy delay time	400		2000	US
Tas	Address startup time	1	2	5	MS
Tbs	Address holding time	1	3	5	MS
Tbsw	SBT trigger time	2			MS
Tcs	CS startup time	2	5	10	MS
Tdh	Data input holding time	40	200	2000	US
Tsck	Serial Clock cycle	200	400	1000	US
Tsckw	Serial Clock pulse width	30	100	4000	US
Tch	CS holding time	20			US
Toutd	Busy output delay time	400		2000	US
Tcd	Reset holding time	3	5		MS
Tcs	Data wake up time	3	5	10	MS
Trd	CS startup time	20			US
Trcd	Waiting time after chip reset	5			MS
Tsd	DATA low level holding time	100	200	1000	US
Tld	DATA high level holding time	200	400	2000	MS

12. One/Two , three line serial interface control flow

13. One serial interface program

13.1. One line serial interface Assembly

```
ORG 0000H
    KEY EQU P1.1    ;
    RST EQU P3.2    ;
    SDA EQU P3.3    ;
DAIFAZHI EQU 50H    ;
    MOV DAIFAZHI,#0H;
    MOV R5,#8       ;

MAIN:
    JB KEY,MAIN
    MOV R6,#10      ;
    LCALL DELAY1MS
    JB KEY,MAIN     ;
    JNB KEY,$       ;
    LCALL one_line  ;
    INC DAIFAZHI    ;
    MOV A,DAIFAZHI
    CJNE A,#128,XX2 ;
XX2: JC XX3
    MOV DAIFAZHI,#0H
XX3: LJMP MAIN

one_line:          ;///
    CLR RST
    MOV R6,#2      ;
    LCALL DELAY1MS
    SETB RST
    MOV R6,#6      ;
    LCALL DELAY1MS
    CLR SDA
    MOV R6,#5      ;
    LCALL DELAY1MS
    MOV A,DAIFAZHI
LOOP:  SETB SDA
    RRC A
    JNC DIDIANPIN ;
    LCALL DELAY300US
    LCALL DELAY300US
    LCALL DELAY300US
```



```
        CLR  SDA
        LCALL DELAY300US
        LJMP LOOP1
DIDIANPIN:          ;
        LCALL DELAY300US
        CLR  SDA
        LCALL DELAY300US
        LCALL DELAY300US
        LCALL DELAY300US
LOOP1:  DJNZ R5,LOOP
        MOV R5,#08H
        SETB SDA
        RET
DELAY300US: MOV R6,#150      ;
        DJNZ R6,$
        RET
DELAY1MS:      ;
L1:  MOV R7,#248
    DJNZ R7,$
    DJNZ R6,L1
    RET
END
```

13.2.One line serial interface C program

```
#include <at89x51.H>
sbit KEY=P1^1;
sbit RST=P3^2;
sbit SDA=P3^3;
void delay1ms(unsigned char count)
{
    unsigned char i,j,k;
    for(k=count;k>0;k--)
        for(i=2;i>0;i--)
            for(j=248;j>0;j--);
}

void delay100us(unsigned char count)
{ unsigned char i;
  unsigned char j;
    for(i=count;i>0;i--)
        for(j=50;j>0;j--);
}
```

```
Send_online(unsigned char addr)
```

```
{
    unsigned char i;
    RST=0;
    delay1ms(2);
    RST=1;
    delay1ms(6);
    SDA=0;
    delay1ms(5);
    for(i=0;i<8;i++)
        {SDA=1;
        if(addr & 1)
            {delay100us(6);
            SDA=0;
            delay100us(2);
            }
        else {
            delay100us(2);
            SDA=0;
            delay100us(6);
            }
        addr>>=1; }
    SDA=1;
}
```

```
main()
```

```
{unsigned char FD=0;
    P3=0XFF;
    while(1)
        {
        if(KEY==0)
            {
            delay1ms(10);
            if(KEY==0)
                {
                Send_online(FD);
                FD++;
                if(FD==208)
                    {
                    FD=0;
                    }
                while(KEY==0);
                }
            }
        }
}
```

}

14. Three lines serial interface program

14.1. Three lines serial interface Assembly

```
ORG 0000H
KEY EQU P1.1    ;
RST EQU P3.2    ;
CS EQU P3.3     ;
SCL EQU P3.4    ;
SDA EQU P3.5    ;
DAIFAZHI EQU 50H ;
MOV DAIFAZHI,#0H;
MOV R5,#8       ;

MAIN:
JB KEY,MAIN
MOV R6,#10      ;
LCALL DELAY1MS
JB KEY,MAIN     ;
JNB KEY,$       ;
LCALL THREE_LINE;
INC DAIFAZHI    ;
MOV A,DAIFAZHI
CJNE A,#128,XX2 ;
XX2: JC XX3
MOV DAIFAZHI,#0H
XX3: LJMP MAIN

THREE_LINE:      ;
CLR RST
MOV R6,#2        ;
LCALL DELAY1MS
SETB RST
MOV R6,#5        ;
LCALL DELAY1MS
CLR CS
MOV R6,#2        ;
LCALL DELAY1MS
MOV A,DAIFAZHI
LOOP:
```

```
        CLR SCL
        RRC A
        MOV SDA,C
        LCALL DELAY50US
        SETB SCL
        LCALL DELAY50US
        DJNZ R5,LOOP
        MOV R5,#08H
        SETB CS
        RET
DELAY50US:  MOV R6,#25      ;
            DJNZ R6,$
            RET
DELAY1MS:   ;
L1:         MOV R7,#248
            DJNZ R7,$
            DJNZ R6,L1
            RET
            END
```

14.2. Three lines serial interface C program

```
#include <at89x51.H>
sbit KEY=P1^1;
sbit RST=P3^2;
sbit CS=P3^3;
sbit SCL=P3^4;
sbit SDA=P3^5;
//sbit DENG=P3^7;
void delay1ms(unsigned char count)
{
    unsigned char i,j,k;
    for(k=count;k>0;k--)
        for(i=2;i>0;i--)
            for(j=248;j>0;j--);
}

void delay100us(void)
{
    unsigned char j;
    for(j=50;j>0;j--);
}
```

```
Send_threelines(unsigned char addr)
{
    unsigned char i;
    RST=0;
    delay1ms(2);
    RST=1;
    delay1ms(5);
    CS=0;
    delay1ms(2);
    for(i=0;i<8;i++)
    {
        SCL=0;
        if(addr & 1)SDA=1;
        else SDA=0;
        addr>>=1;
        delay100us();
        SCL=1;
        delay100us();
    }
    CS=1;
}
```

```
main()
{
    unsigned char FD=0;
    P3=0XFF;
    while(1)
    {
        if(KEY==0)
        {
            delay1ms(10);
            if(KEY==0)
            {
                Send_threelines(FD);
                FD++;
                if(FD==208)
                {
                    FD=0;
                }
                while(KEY==0);
            }
        }
    }
}
```

15. Supply information

Package	Model	Duration Äat 6KHz Å
DIP16	WTV020-16P	20s
SOP16	WTV020-16S	20s
TSSOP16	WTV020-TSSOP16	20s
SOP20/SSOP20	WTV020-20S/SS	20s
DIP16	WTV010-16P	10s
SOP16	WTV010-16S	10s

16. Versions

Version	Date	Description
V1.8	2011-4-17	Origin